

TOOLS FOR THE SPECIALIST ACCESSORIES FOR RECIPROCATING SAWS

PNEUMATIC 

HYDRAULIK 

ELECTRIC 

ATEX
Guideline 94/9 EC

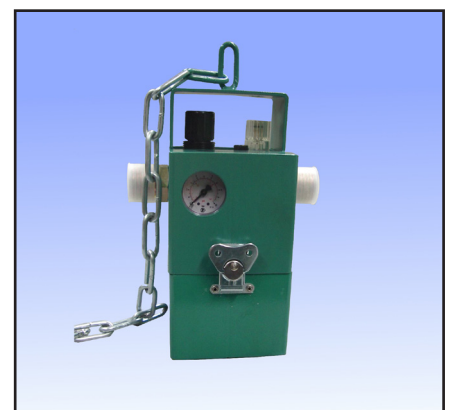
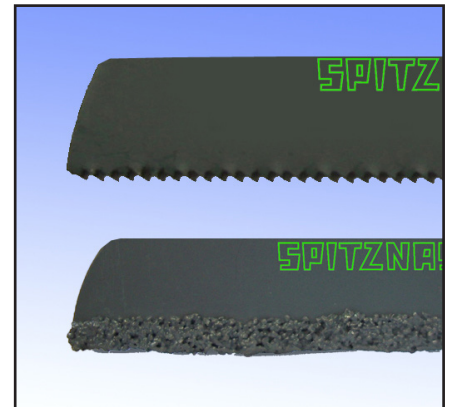

CLAMPS

Clamps for pipes

Order no.	Description	Needed saw blade length pipe dia. + ... (mm)	for pipes up to dia. (mm)
5 1202 9960	Clamp	130	325
5 1202 8940	Clamp	130	530

Bow guides for clamps

Order No.	Description	Min. saw blade length (mm)	for pipes up to dia. (mm)
5 1207 9970	Bow guide	500	325
5 1207 8910	Bow guide	700	530
5 1212 9970	Bow guide	900	600

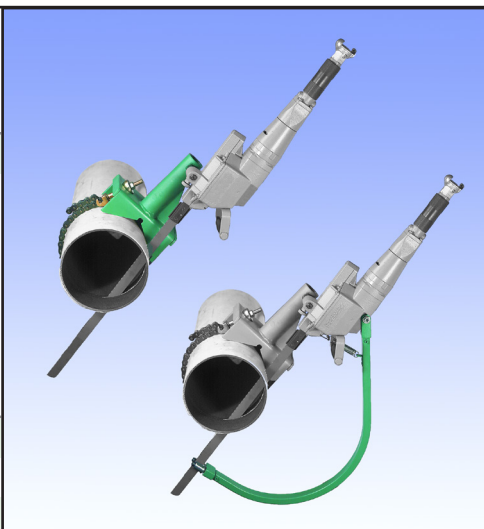

Clamp with bow guide for pipes

Order no.	Description	Min. saw blade length (mm)	for pipes up to dia. (mm)
5 1207 9930	Clamp with bow guide	500	325
5 1207 8930	Clamp with bow guide	700	530

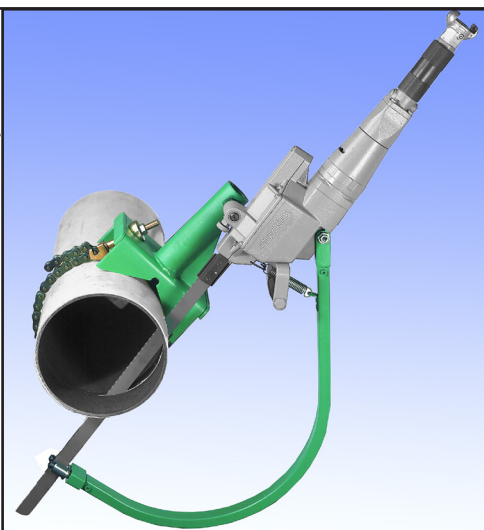

Extension chain for clamps

Order no.	Description	for pipes up to dia. (mm)
5 1201 9010	Extension chain (0,5 m) complete	250
5 1201 9030	Extension chain (1,0 m) complete	325
5 1201 9020	Extension chain (2,0 m) complete	600



Quick spanner for clamps

Order no.	Description
5 1202 9970	Quick spanner for pipes up to diameter 325 mm
5 1207 8140	Handle complete (without picture)

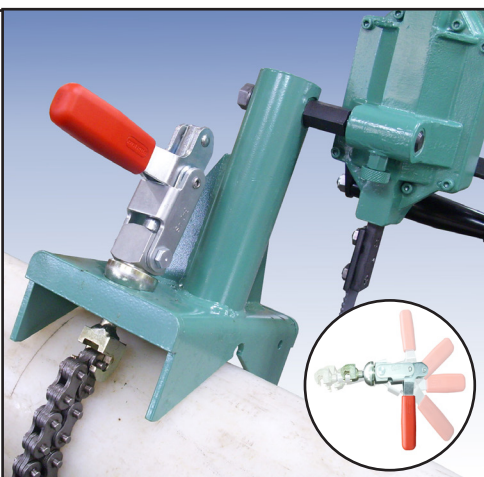

CLAMPS

Automatic power feed clamps for pipes

Order no.	Description	for pipes up to dia. (mm)
5 1208 9940	with automatic feed with pneumatic cylinder	530
5 1208 9990	with automatic feed with spring cylinder	530

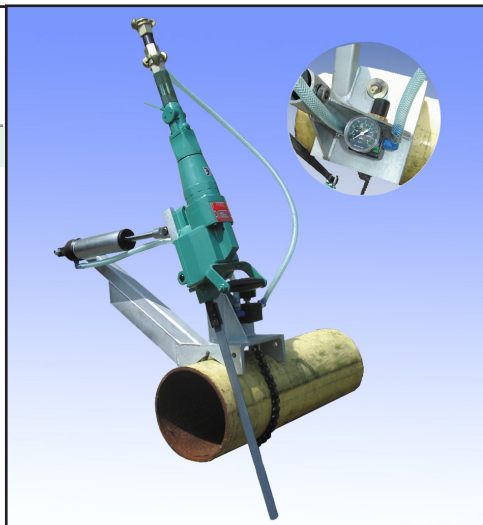

Magnetic clamp

Order no.	Description
5 1213 9500	Magnetic clamp



Clamps for profiles

Order no.	Description
5 1202 8970	up to 290 mm with screw lever, bearing bolt and adjustable abutment
5 1207 9940	up to 340 mm with screw lever, bearing bolt and adjustable abutment



Clamp for pipes

Order no.	Description	for pipes up to dia. (mm)
5 1207 9910	Clamp	150

Clamps for underground roof supports

Order no.	Description
5 1208 9910	Constant-velocity joint clamp with power feed
5 1214 9000	Double-screw clamp

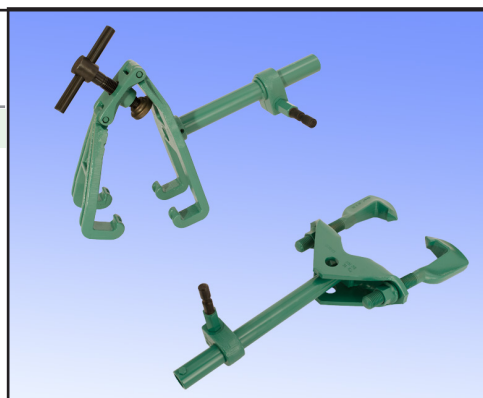

SAW BLADES

Other lengths on request.

All SPITZNAS saw blades cut on backward stroke.
Length of blade = Operating length + 130 mm.



Order no.

Teeth per inch
Length (mm)
Width (mm)
Height (mm)
Quality

						Plastic	GFK-Pipe	Hardboard	Asbestos cement	Concrete reinforced	Clinker	Aluminium (solid material)	Cast iron	Ductile iron (cement coated iron)	Tar coated cast iron pipe	Steel (solid material)	Reinforcing bar	Non-ferrous metal (non-precious)	Non-ferrous metal (precious)	Stainless steel	Rust-resistant steel	High stress steel (< 600 N/mm ²)
HSS																						
9 2501 0050	6	200	25	1.5	☆☆☆	x			x			x										
9 2501 0120	6	300	25	1.5	☆☆☆	x			x			x										
9 2501 0190	6	400	25	1.5	☆☆☆	x			x			x										
9 2501 0230	6	500	28	2.0	☆☆☆	x			x			x										
9 2501 0470	6	600	28	2.0	☆☆☆	x			x			x										
9 2501 0310	6	770	28	2.0	☆☆☆	x			x			x										
9 2501 0630	8	200	25	1.5	☆☆☆	x		x					x			x			x			
9 2501 0660	8	400	25	1.5	☆☆☆	x		x					x			x			x			
9 2501 0710	8	600	28	2.0	☆☆☆	x		x					x			x			x			
9 2501 0440	12	200	28	2.0	☆☆☆	x		x					x			x			x			
9 2501 0130	12	300	25	1.5	☆☆☆	x		x					x			x			x			
9 2501 0200	12	400	25	1.5	☆☆☆	x		x					x			x			x			
9 2501 0450	12	500	28	2.0	☆☆☆	x		x					x			x			x			
9 2501 0670	12	530	28	2.0	☆☆☆	x		x					x			x			x			
9 2501 0720	12	770	28	2.0	☆☆☆	x		x					x			x			x			
9 2501 0690	12	940	28	2.0	☆☆☆	x		x					x			x			x			
9 2501 0020	14	150	25	1.5	☆☆☆													x			x	x
9 2501 0060	14	200	25	1.5	☆☆☆													x			x	x
9 2501 0070	14	250	25	1.5	☆☆☆													x			x	x
9 2501 0140	14	300	25	1.5	☆☆☆													x			x	x
9 2501 0210	14	400	25	1.5	☆☆☆													x			x	x
9 2501 0240	14	500	28	2.0	☆☆☆													x			x	x
9 2501 0460	14	600	28	2.0	☆☆☆													x			x	x
9 2501 0300	14	770	28	2.0	☆☆☆													x			x	x
9 2501 0640	16	200	25	1.5	☆☆☆													x			x	x
9 2501 0610	16	300	25	1.5	☆☆☆													x			x	x
9 2501 0620	16	400	25	1.5	☆☆☆													x			x	x
HSS-SL																						
9 2501 0680	12	530	28	2.0	☆☆☆	x		x					x			x			x	x		x
9 2501 0730	12	770	28	2.0	☆☆☆	x		x					x			x			x	x		x
9 2501 0320	16	150	25	1.5	☆☆☆													x			x	x
9 2501 0330	16	200	25	1.5	☆☆☆													x			x	x
9 2501 0340	16	250	25	1.5	☆☆☆													x			x	x
9 2501 0350	16	300	25	1.5	☆☆☆													x			x	x
9 2501 0600	16	350	25	1.5	☆☆☆													x			x	x
9 2501 0360	16	400	25	1.5	☆☆☆													x			x	x
9 2501 0370	16	500	28	2.0	☆☆☆													x			x	x
9 2501 0380	16	770	28	2.0	☆☆☆													x			x	x
CARBIDE COATED-SL																						
9 2504 0500	-	300	25	2.0	☆☆☆								x	x	x							
9 2504 0510	-	400	25	2.0	☆☆☆								x	x	x							
9 2504 0520	-	500	28	2.0	☆☆☆								x	x	x							
9 2504 0530	-	600	28	2.0	☆☆☆								x	x	x							
9 2504 0540	-	700	28	2.0	☆☆☆								x	x	x							
9 2504 0550	-	770	28	2.0	☆☆☆								x	x	x							
CARBIDE TIPPED																						
9 2504 0610	4	300	50	-	☆☆☆		x			x	x		x	x	x							
9 2504 0620	4	400	50	-	☆☆☆		x			x	x		x	x	x							
9 2504 0630	4	500	50	-	☆☆☆		x			x	x		x	x	x							
9 2504 0640	4	600	50	-	☆☆☆		x			x	x		x	x	x							
9 2504 0650	4	770	50	-	☆☆☆		x			x	x		x	x	x							

Quality class : ☆☆☆ standard

☆☆☆ high quality

☆☆☆ highest quality

SPITZNAS

Maschinenfabrik GmbH, Fellerstraße 4, D-42555 Velbert, Germany
Tel: +49-(0)2052-605-0 Fax: +49-(0)2052-605-29
E-Mail: sales@spitznas.com Internet: http://www.spitznas.com

05/15 E