



Screwdriving technology

Automation

Air motors

Air tools

DEPRAG

Feeding Technology

Press-Insertion Systems

Efficient placement and setting of connection-elements

- Streamlining your Assembly
- Optimizing the assembly process
- High product output
- Ergonomic and comfortable for the Operator
- Simple Start-Up

The handheld Inserting Machine can be used where the efficient and process reliable press-insertion and placement operations are done by hand. Our handheld and stationary press-insertion tools are combined with the suitable feeder.

Our Press-Insertion systems are an adaptive solution for many different applications. Some of the connection-elements, such as rivets, pins, sleeves and balls can be processed with this system both process reliable and efficient.



DEPRAG Press-Insertion Systems consist of:

- a feeding system (vibratory- or sword feeder)
- a handheld or stationary press-insertion tool
- a maintenance unit
- an electronic control

The feeder needs a suitable nosepiece ball-type or split-type, which is adapted to fit your fastener and application.

Basically, two different types of standard screwfeeders - Vibratory Feeder or Sword (Segment) Feeder - are available.



PRESS-INSERTION DEVICES FOR HANDHELD APPLICATIONS

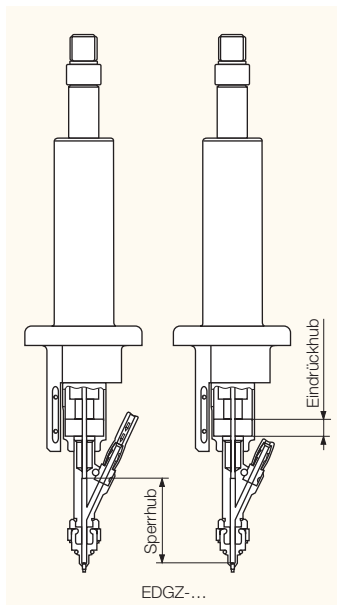
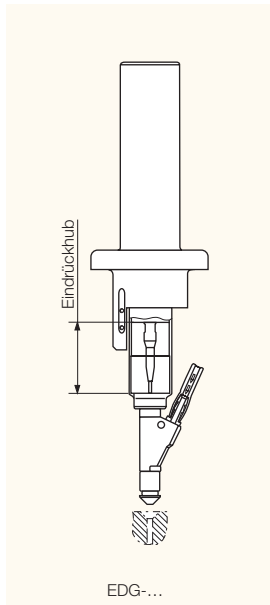

DEPRAG press-insertion devices for handheld applications excel through the ergonomic form of the handle and the high efficiency when connected to a suitable feeder.

Two different machine designs are available:

■ **Model EDG with one insertion stroke**

An operator fully guides the down-stroke of the insertion tool. The down-pressure asserted by the Operator supports the pin-insertion.

■ **Model EDGZ with one insertion stroke and an additional locking stroke**

A cylinder integrated into the insertion-tool activates the locking-stroke. The insertion-lock assures a firm overhang of the fastener from the nosepiece. An involuntary push-back of the component is eliminated. The Operator only performs a short stroke, which is necessary for the actual press-insertion.

Application Examples for actual solutions with a handheld tool:

- Press-insertion of grooved pins to hold seat-covers to a car seat for kids
- Assembly of rubber-feet to the bottom of a telephone housing
- Install contact pins into cell-phone shells
- Insertion of steel rivets to allow riveting at a later time
- Pre-assembly of safety rivets into miniature model trains
- Insertion of expansion-rivets to attach a PC-board to a housing frame

TECHNICAL DATA FOR HANDHELD PRESS-INSERTION DEVICES

For rivets and pins from 1 – 8 mm shaft-diameter and a max. length up to 35 mm
For balls up to 12 mm diameter

Design	Type	EDG-...	EDGZ-...
Insertion stroke		yes	yes
Locking stroke		no	yes
Maximum dimension of fastener to be processed		Please refer to the dimensional information shown in our feeder brochure D 3820 E	
Reloading signal using an inductive BERO		yes	yes
Pneumatic connections for locking stroke	up to 60 mm stroke over 60 mm stroke	– –	1 (forward stroke / return by spring) 2 (forward and return stroke)
Operating pressure		6.3 bar / 90 PSI	6.3 bar / 90 PSI

The technical design depends on customer requirements. The sequence control of the feeder runs the entire operation.

Optional Equipment

Balancer	Part no.	827678 A	827678 A
Special accessories		Split type nosepiece with support body Nosepiece ball type - double Mouthpiece tiltable	

PRESS-INSERTION DEVICES FOR STATIONARY APPLICATIONS

Customer Specific Solutions

For stationary applications, the supply- and insertion-movement is done by a cylinder.

The use of sensors allows a multitude of application possibilities for many different types of connection elements.

So, besides rivets, pins, sleeves and balls, etc., the stationary insertion system can also process asymmetrical parts.

Please contact us to discuss your special applications!

Application Example:

A threaded bushing is fed via vibratory feeder to a tiltable mouthpiece. It is then pressed into a component, accurately and repeatedly, to a pre-determined height.

Besides press-insertion systems, DEPRAG also offers total solutions with integrated depth-controls, presence- and positioning controls, and customized equipment up to and including complex assembly installations.

All essential key technologies are made in house.

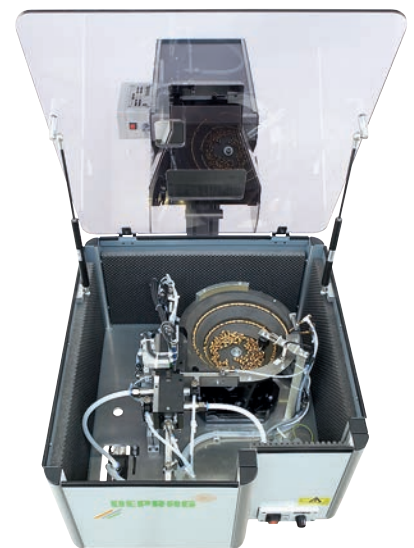

DEPRAG

DEPRAG SCHULZ GMBH u. CO.

P.O. Box 1352, D-92203 Amberg, Germany
Carl-Schulz-Platz 1, D-92224 Amberg
Phone (+49) 9621 371-0, Fax (+49) 9621 371-120
www.deprag.com
info@deprag.de



CERTIFIED AS PER DIN EN ISO 9001
